

**Constant current independent dimmable driver**  
**PUL-A Series suffix D(DALI-2+pushDIM+1-10V/10V PWM)**

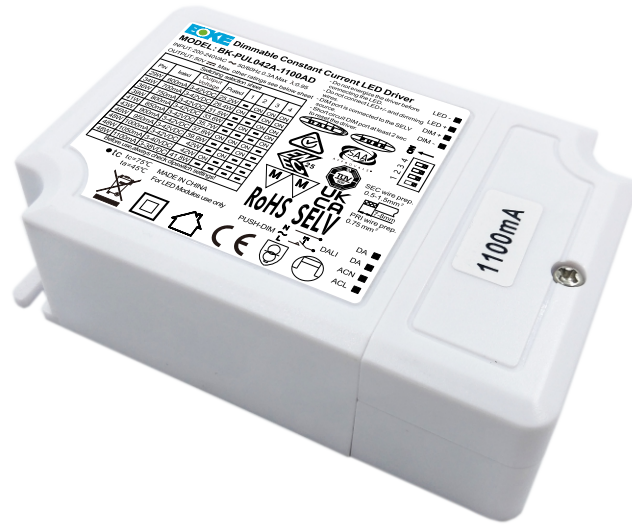

**Features**

- Support DALI-2+pushDIM+1-10V/10V PWM dimming mode
- 10/15-level current output can be realized by DIP-switch
- Soft dimming and flicker-free at any brightness, meets the new requirements of ErP certification
- Using HPC patented technology at any dimming level, the brightness between lights is same
- Standby power input<0.5W, meets the requirements of ErP certification
- High PF, high efficiency, low THD
- Screw-free and pressing type strain relief, supports thicker cables and is easier to install
- Independent input and output strain relief, stronger wiring
- Intelligent LED hot-plug protection function
- SELV and Class II design, suitable for use outside of the light
- Passed ENEC,CE,UKCA,DALI-2,EL and other certifications
- IP20 protection grade, indoor use
- Nominal life-time up to 100,000 h
- 5-year guarantee

**Interfaces**

- DALI-2(DALI-2 DT6)
- PUSH(pushDIM)
- DIM(1-10V / 10V PWM )

**Functions**

- Support central emergency application (dimming normal in DC input)
- Support self-contained emergency application
- Protective features (short-circuit,no-load, hot plug-in protection )

**Suitable for lights**

- Suitable for lights with independent drivers such as downlights, spotlights, panel lights, etc
- Not suitable for lights with built-in drivers

**Typical applications**

- LED indoor lighting
- LED office lighting
- LED commercial lighting

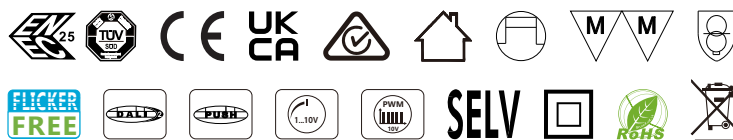



## Technical data

Product model	BK-PUL030A-0700AD
<b>Output parameters</b>	
Regulation method	Constant Current
Rated output current range	0.25-0.7A
Rated output voltage range	3-42VDC
Rated output power	29.4W Max
Output current adjustment	DIP S.W.(10 levels)
Output current ripple LF	±1%
Output current accuracy	±2%
Linear regulation	±1%
Load regulation	±1%
No load output voltage	50VDC
Flicker-free(typical)	Modulation depth =0.106% (100 Hz), Pst LM ≤ 0.000, SVM ≤ 0.003,(The above parameters are obtained from testing the panel lights)
<b>Input parameters</b>	
Rated input voltage range	200-240VAC 200-240VDC
Input voltage range	180-264VAC 200-264VDC
Input voltage shock	<380V AC
Input current	<0.2A (Rated input voltage)
Input frequency	0/50/60Hz
Input PF/Input DF	PF>0.95 (230V AC & Full load),DF>0.95 (230V AC & Full load)
Input THD	10% (230V AC & Full load)
Efficiency(typical)	87% (230V AC & Full load)
In-rush current	4.33A peak ,164us duration(50 % Ipeak), see the description below for details
Start/Switchover/Turn off	<0.7s(AC start),<0.7s(DC start),<0.3s(AC/DC switchover),<0.5s(Turn off)
Switching cycles	> 50,000 switching cycles
Power consumption	Full load(Pin):33.7W, No load(Pno): N/A, On stand-by(Psb) : <0.5W, Network stand-by(Pnet) : N/A
<b>Safety</b>	
Withstand voltage	I/P-O/P:3750V AC, I/P-DALI: 1500V AC.
Mains surge capability	L-N:2KV
Leakage current	<0.7mA (230V AC & Full load)
Isolation resistance	I/P-O/P:100MΩ/500Vdc/25°C/70% RH
<b>Control interface</b>	
DALI dimming port	Voltage range: 9.5-22.5V, typical 16V, interface current consumption: 1.8mA
pushDIM dimming port	Voltage range: 180-264V 50/60Hz
1-10V 3in1 dimming port	Voltage range: 0-10V, interface current consumption: 0.3mA
Auxiliary power supply	N/A
Dimming range	3-100%
Dimming drive mode	AM(amplitude modulation)
<b>Emergency support</b>	
Central emergency system	Supported(Under DC input conditions)
Self-contained emergency	Supported
<b>Environment &amp; Life time</b>	
Operating temperature	Ta=-20-45°C
Case temperature	Tc=75°C
Operating humidity	5-85% RH, not condensed
Storage temp./humidity	-40-80°C, 5-85% RH, not condensed
IP grade	IP20
MTBF	500,000H,MIL-HDBK-217F(25°C)
Life-time	Nominal life-time up to 100,000 h, see the description below for details
Vibration resistant	10~500Hz,5G 12min./1cycle,period for 72min. each along X,Y,Z axes
Acoustic Noise	<25dB(30cm, Normal operation)
Environmental protection	RoHS
<b>Certifications and standards</b>	
Certification	ENEC, RCM, UKCA, CE, CCC, DALI-2, EL
Safety	EN61347-1, EN61347-2-13, EN62384
EMC	EN55015, EN61000-3-2, EN61000-3-3, EN61000-4-2,3,4,5,6,8,11, EN61547
DALI-2	IEC 62386-101(DALI-2), IEC 62386-102(DALI-2), IEC 62386-207(DALI-2)
EL	Compatible IEC 61347-2- 13 Annex J, compatible with EN 60598-2-22 and EN 50172
RF	N/A

## Remarks

- By default, all parameter are measured at 230VAC input, full load and 25°C of ambient temperature.
- The driver can not be installed inside the light. when the driver is used with the light, the EMC of the whole light needs to be tested.

**Technical data**

Product model	BK-PUL042A-0700BD	BK-PUL042A-1100AD	
<b>Output parameters</b>			
Regulation method	Constant Current	Constant Current	
Rated output current range	0.25-0.7A	0.6-1.1A	
Rated output voltage range	3-60/64/70/76/84VDC	3-38/40/42VDC	
Rated output power	42W Max	42W Max	
Output current adjustment	DIP S.W(10 levels)	DIP S.W(10 levels)	
Output current ripple LF	±1%	±1%	
Output current accuracy	±2%	±2%	
Linear regulation	±1%	±1%	
Load regulation	±1%	±1%	
No load output voltage	100VDC	50VDC	
Flicker-free(typical)	Modulation depth =0.440% (100 Hz), Pst LM ≤ 0.003, SVM ≤ 0.007,(The above parameters are obtained from testing the panel lights)		
<b>Input parameters</b>			
Rated input voltage range	200-240VAC 200-240VDC		
Input voltage range	180-264VAC 200-264VDC		
Input voltage shock	<380V AC		
Input current	<0.3A (Rated input voltage)		
Input frequency	0/50/60Hz		
Input PF/Input DF	PF>0.95 (230V AC & Full load),DF>0.95 (230V AC & Full load)		
Input THD	10% (230V AC & Full load)		
Efficiency(typical)	88% (230V AC & Full load)		
In-rush current	4.88A peak ,154us duration(50 % Ipeak), see the description below for details		
Start/Switchover/Turn off	<0.7s(AC start),<0.7s(DC start),<0.3s(AC/DC switchover),<0.5s(Turn off)		
Switching cycles	> 50,000 switching cycles		
Power consumption	Full load(Pin):48W, No load(Pno): N/A, On stand-by(Psb) : <0.5W, Network stand-by(Pnet) : N/A		
<b>Safety</b>			
Withstand voltage	I/P-O/P:3750V AC, I/P-DALI: 1500V AC.		
Mains surge capability	L-N:2KV		
Leakage current	<0.7mA (230V AC & Full load)		
Isolation resistance	I/P-O/P:100MΩ/500Vdc/25°C/70% RH		
<b>Control interface</b>			
DALI dimming port	Voltage range: 9.5-22.5V, typical 16V, interface current consumption: 1.8mA		
pushDIM dimming port	Voltage range: 180-264V 50/60Hz		
1-10V 3in1 dimming port	Voltage range: 0-10V, interface current consumption: 0.3mA		
Auxiliary power supply	N/A		
Dimming range	3-100%	2-100%	
Dimming drive mode	AM(amplitude modulation)		
<b>Emergency support</b>			
Central emergency system	Supported(Under DC input conditions)		
Self-contained emergency	Supported		
<b>Environment &amp; Life time</b>			
Operating temperature	Ta=-20-45°C		
Case temperature	Tc=75°C		
Operating humidity	5-85% RH, not condensed		
Storage temp./humidity	-40-80°C, 5-85% RH, not condensed		
IP grade	IP20		
MTBF	500,000H,MIL-HDBK-217F(25°C)		
Life-time	Nominal life-time up to 100,000 h, see the description below for details		
Vibration resistant	10~500Hz,5G 12min./1cycle,period for 72min. each along X,Y,Z axes		
Acoustic Noise	<25dB(30cm, Normal operation)		
Environmental protection	RoHS		
<b>Certifications and standards</b>			
Certification	ENEC, RCM, UKCA, CE, CCC, DALI-2, EL		
Safety	EN61347-1, EN61347-2-13, EN62384		
EMC	EN55015, EN61000-3-2, EN61000-3-3, EN61000-4-2,3,4,5,6,8,11, EN61547		
DALI-2	IEC 62386-101(DALI-2), IEC 62386-102(DALI-2), IEC 62386-207(DALI-2)		
EL	Compatible IEC 61347-2- 13 Annex J, compatible with EN 60598-2-22 and EN 50172		
RF	N/A		

**Remarks**

- 1.By default, all parameter are measured at 230VAC input, full load and 25°C of ambient temperature.
- 2.The driver can not be installed inside the light. when the driver is used with the light, the EMC of the whole light needs to be tested.

## Technical data

Product model	BK-PUL060A-2000AD
<b>Output parameters</b>	
Regulation method	Constant Current
Rated output current range	0.8-2.0A
Rated output voltage range	3-30/32/34/36/38/40/42VDC
Rated output power	61.2W Max
Output current adjustment	DIP S.W(15 levels)
Output current ripple LF	±1%
Output current accuracy	±2%
Linear regulation	±1%
Load regulation	±1%
No load output voltage	50VDC
Flicker-free(typical)	Modulation depth =0.183% (100 Hz), Pst LM ≤ 0.002, SVM ≤ 0.006,(The above parameters are obtained from testing the panel lights)
<b>Input parameters</b>	
Rated input voltage range	200-240VAC 200-240VDC
Input voltage range	180-264VAC 200-264VDC
Input voltage shock	<380V AC
Input current	<0.4A (Rated input voltage)
Input frequency	0/50/60Hz
Input PF/Input DF	PF>0.95 (230V AC & Full load),DF>0.95 (230V AC & Full load)
Input THD	10% (230V AC & Full load)
Efficiency(typical)	90% (230V AC & Full load)
In-rush current	9.51A peak ,178us duration(50 % Ipeak), see the description below for details
Start/Switchover/Turn off	<0.7s(AC start),<0.7s(DC start),<0.3s(AC/DC switchover),<0.5s(Turn off)
Switching cycles	> 50,000 switching cycles
Power consumption	Full load(Pin):69W, No load(Pno): N/A, On stand-by(Psb) : <0.5W, Network stand-by(Pnet) : N/A
<b>Safety</b>	
Withstand voltage	I/P-O/P:3750V AC, I/P-DALI: 1500V AC.
Mains surge capability	L-N:2KV
Leakage current	<0.7mA (230V AC & Full load)
Isolation resistance	I/P-O/P:100MΩ/500Vdc/25°C/70% RH
<b>Control interface</b>	
DALI dimming port	Voltage range: 9.5-22.5V, typical 16V, interface current consumption: 1.8mA
pushDIM dimming port	Voltage range: 180-264V 50/60Hz
1-10V 3in1 dimming port	Voltage range: 0-10V, interface current consumption: 0.3mA
Auxiliary power supply	N/A
Dimming range	1-100%
Dimming drive mode	AM(amplitude modulation)
<b>Emergency support</b>	
Central emergency system	Supported(Under DC input conditions)
Self-contained emergency	Supported
<b>Environment &amp; Life time</b>	
Operating temperature	Ta=-20-45°C
Case temperature	Tc=80°C
Operating humidity	5-85% RH, not condensed
Storage temp./humidity	-40-80°C, 5-85% RH, not condensed
IP grade	IP20
MTBF	500,000H,MIL-HDBK-217F(25°C)
Life-time	Nominal life-time up to 100,000 h, see the description below for details
Vibration resistant	10~500Hz,5G 12min./1cycle,period for 72min. each along X,Y,Z axes
Acoustic Noise	<25dB(30cm, Normal operation)
Environmental protection	RoHS
<b>Certifications and standards</b>	
Certification	ENEC, RCM, UKCA, CE, CCC, DALI-2, EL
Safety	EN61347-1, EN61347-2-13, EN62384
EMC	EN55015, EN61000-3-2, EN61000-3-3, EN61000-4-2,3,4,5,6,8,11, EN61547
DALI-2	IEC 62386-101(DALI-2), IEC 62386-102(DALI-2), IEC 62386-207(DALI-2)
EL	Compatible IEC 61347-2- 13 Annex J, compatible with EN 60598-2-22 and EN 50172
RF	N/A

## Remarks

- 1.By default, all parameter are measured at 230VAC input, full load and 25°C of ambient temperature.
- 2.The driver can not be installed inside the light. when the driver is used with the light, the EMC of the whole light needs to be tested.

Electrical values

**BK-PUL030A-0700AD**

Operating window

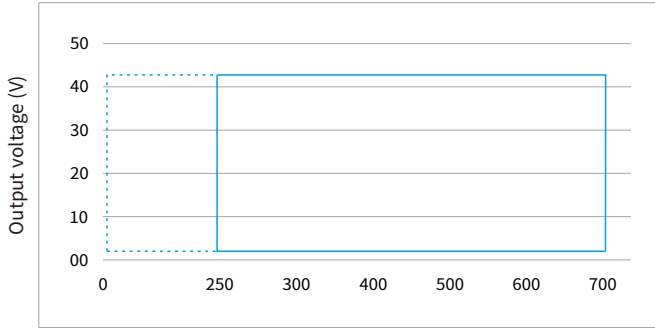

Output current(mA) — Operating window 100 %  
 ..... Operating window dimmed

Operating window

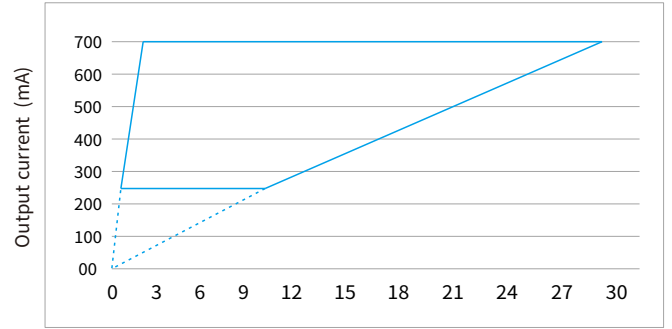

Output power(W) — Operating window 100 %  
 ..... Operating window dimmed

Efficiency vs load

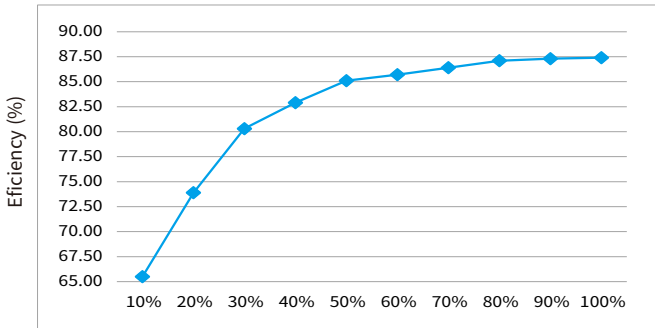

Load(%)

THD vs. Load

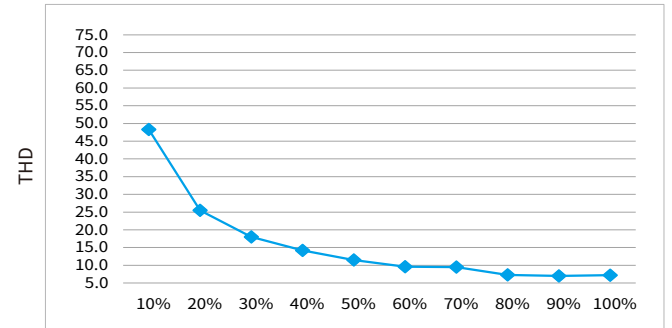

Load(%)

Power factor vs. Load

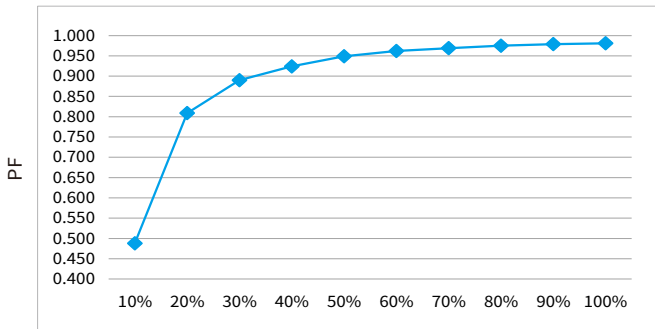

Load(%)

Displacement factor vs. Load

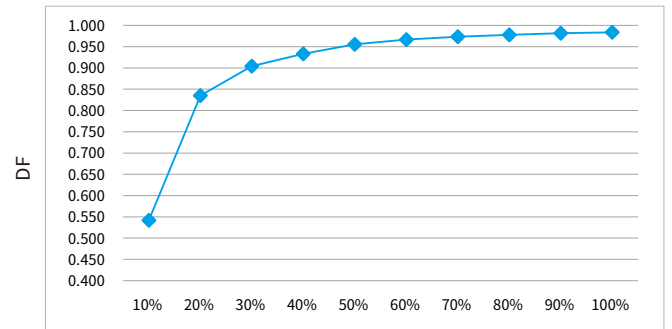

Load(%)

**BK-PUL042A-0700BD**

Operating window

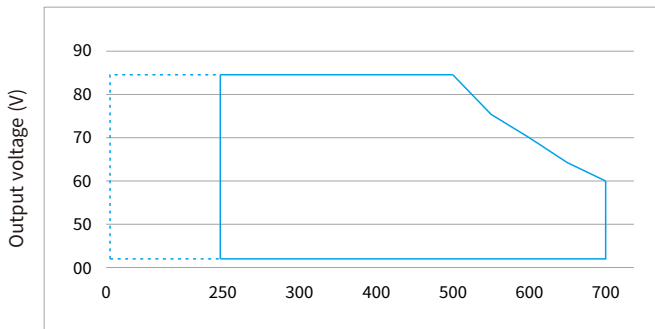

Output current(mA) — Operating window 100 %  
 ..... Operating window dimmed

Operating window

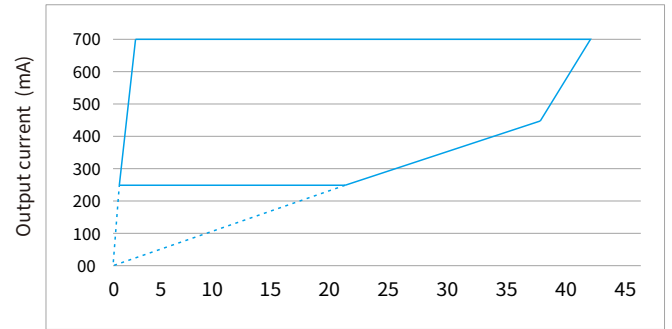

Output power(W) — Operating window 100 %  
 ..... Operating window dimmed

**BK-PUL042A-0700BD (Continue)**

Efficiency vs load

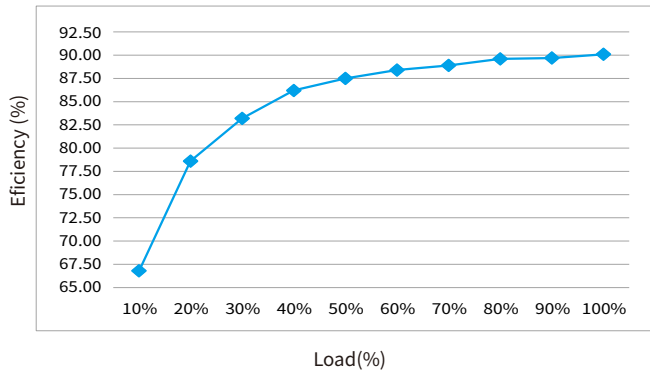

THD vs. Load

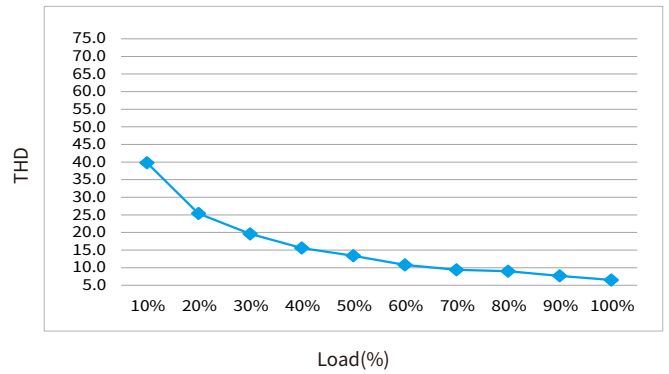

Power factor vs. Load

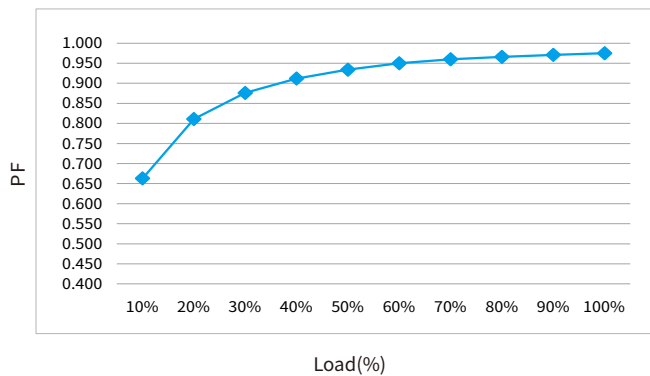

Displacement factor vs. Load

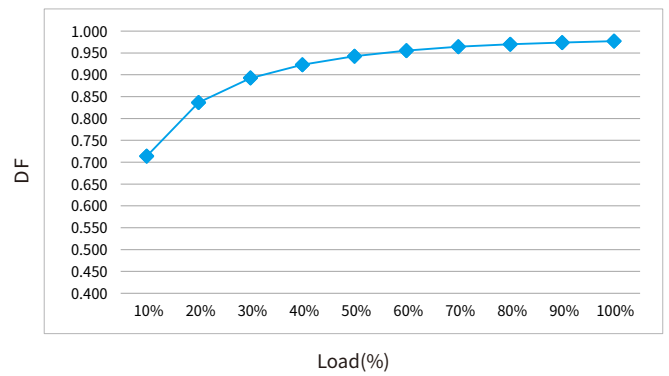

**BK-PUL042A-1100AD**

Operating window

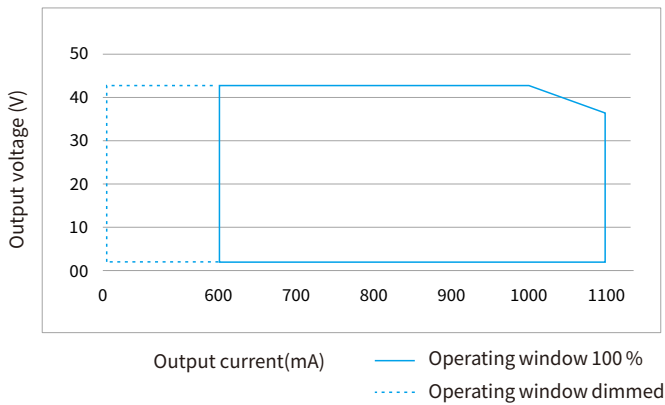

Operating window

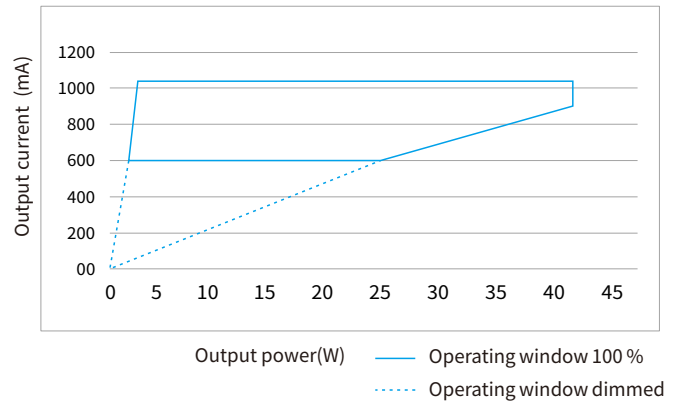

Efficiency vs load

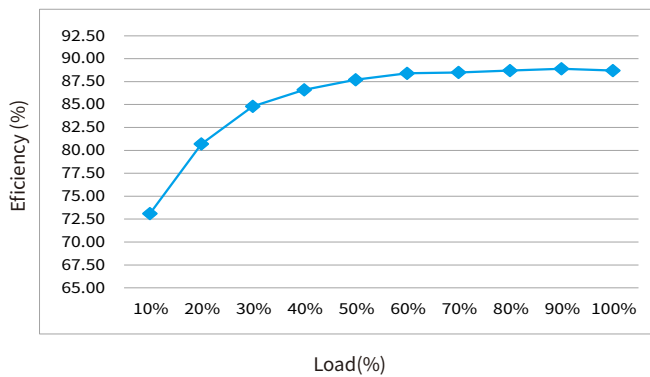

THD vs. Load

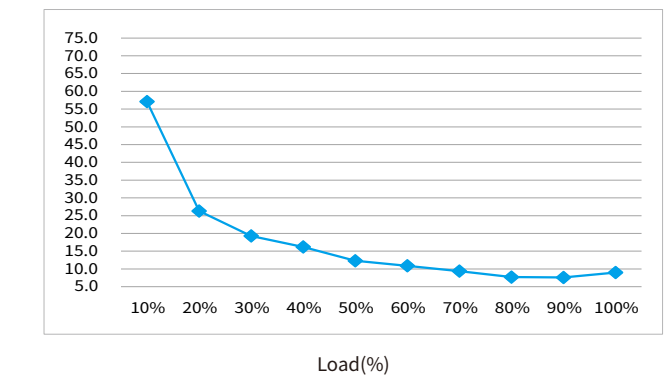

**BK-PUL042A-1100AD (Continue)**

Power factor vs. Load

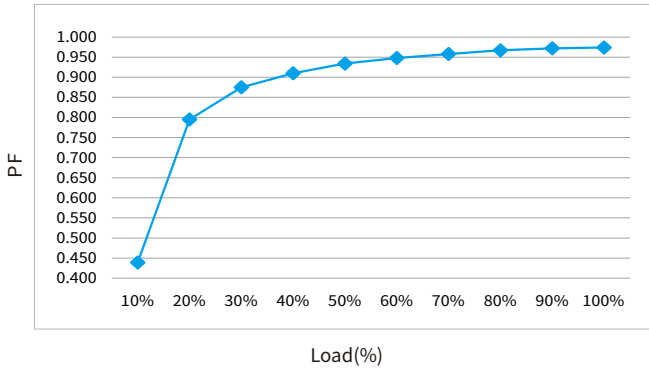

Displacement factor vs. Load

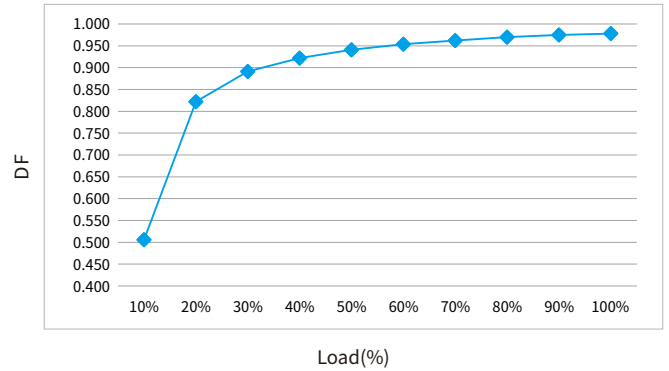

**BK-PUL060A-2000AD**

Operating window

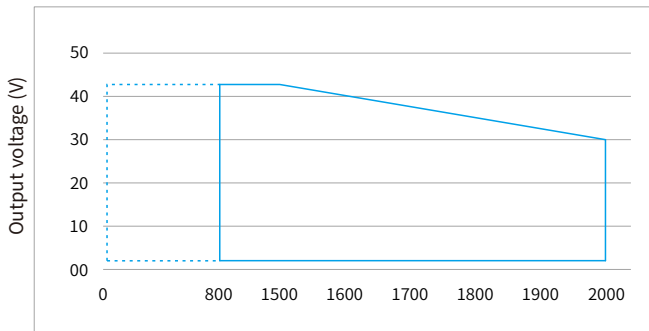

Output current (mA) — Operating window 100%  
 ..... Operating window dimmed

Operating window

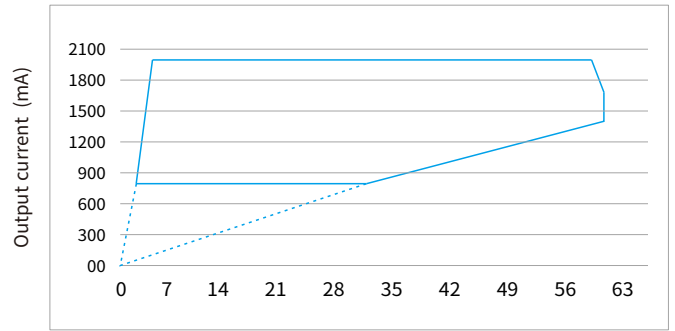

Output power (W) — Operating window 100%  
 ..... Operating window dimmed

Efficiency vs load

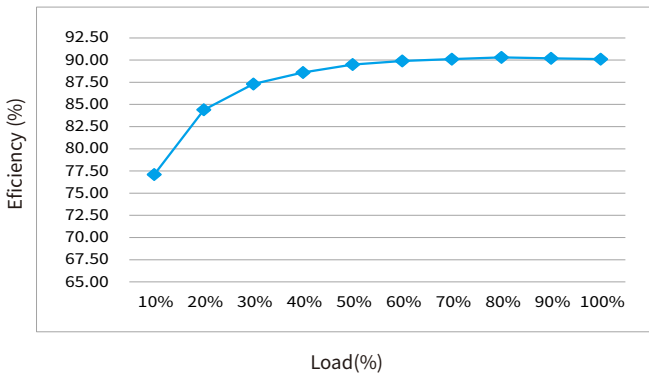

THD vs. Load

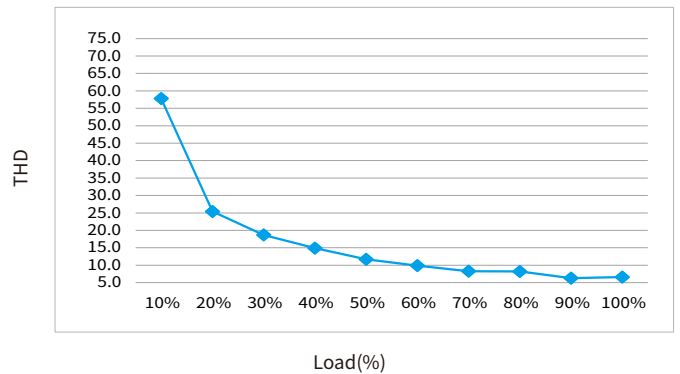

Power factor vs. Load

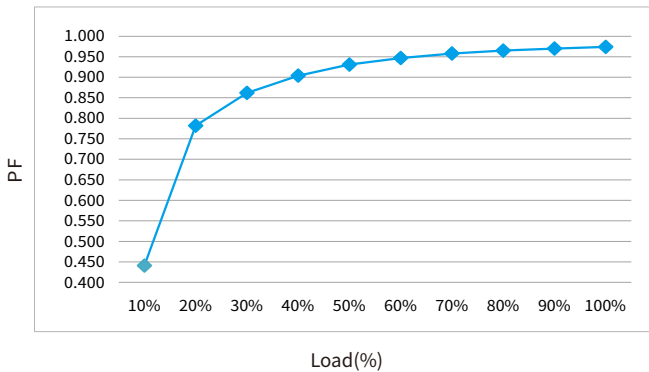

Displacement factor vs. Load

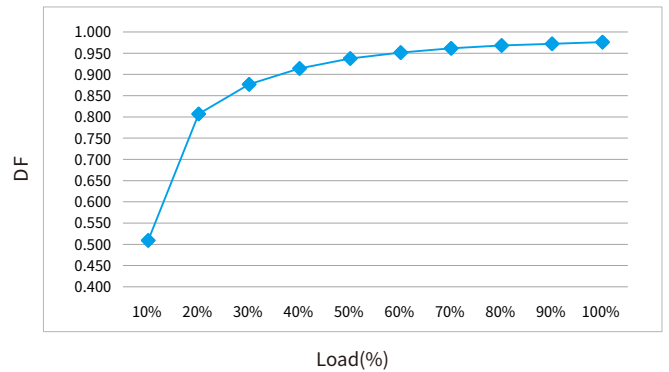

Expected life-time

**BK-PUL030A-0700AD**

Life-time vs. case temperature

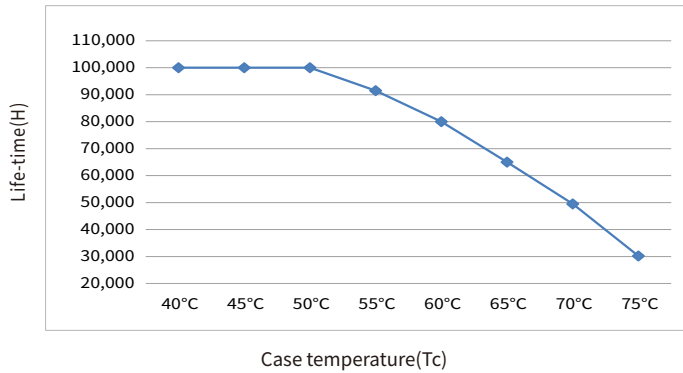

**BK-PUL042A-0700BD**

Life-time vs. case temperature

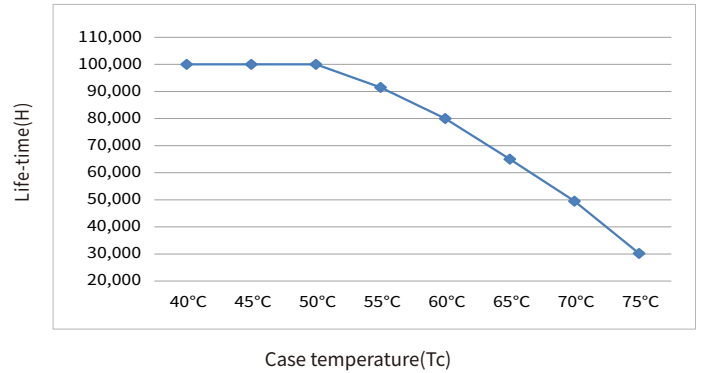

**BK-PUL042A-1100AD**

Life-time vs. case temperature

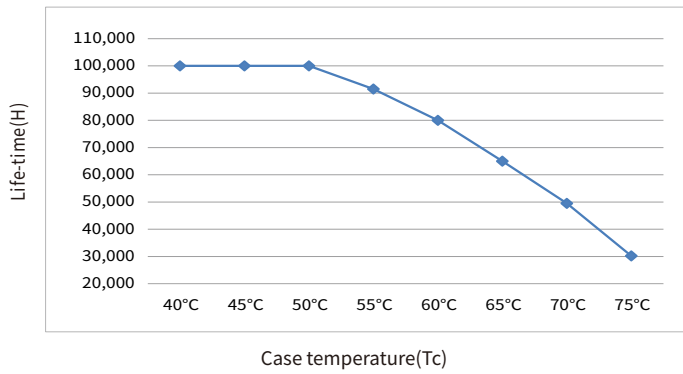

**BK-PUL060A-2000AD**

Life-time vs. case temperature

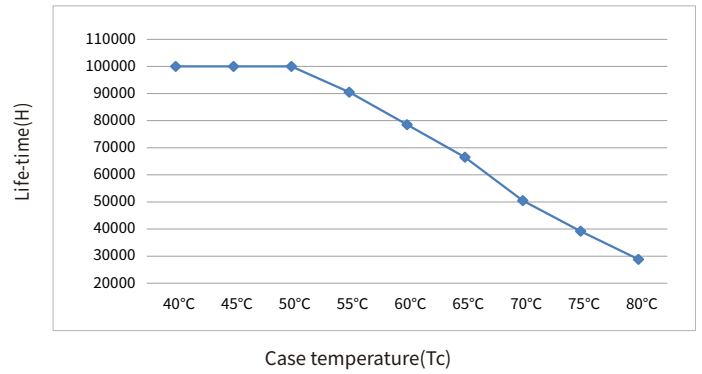

- The life-time of the LED driver is shown in the figure above (calculated based on the 90% survival rate).
- The relation of tc to ta temperature depends also on the luminaire design.

## Surge

Model	I <sub>peak</sub>	T <sub>width</sub>	Condition	Relative number of MCB															
				B10	B13	B16	B20	B25	C10	C13	C16	C20	C25	D10	D13	D16	D20	D25	
BK-PUL030A-0700AD	4.33A	164us	AC 230V, Full load, Cold start, T <sub>a</sub> ≤ 30°C, MCB is not installed side by side	46	60	74	92	116	46	60	74	92	116	46	60	74	92	116	
BK-PUL042A-1100AD	4.88A	154us		33	43	52	65	82	33	43	52	65	82	33	43	52	65	82	
BK-PUL060A-2000AD	9.51A	178us		23	30	37	46	57	23	30	37	46	57	23	30	37	46	57	

### Remarks

- The number of drives mounted under different MCBs in the table is the maximum value. Please do not exceed this number during installation.
- Calculation uses typical values from ABB series S200 as a reference.
- Different brands and models of miniature circuit breakers, the number of drives mounted will be slightly different.
- If the ambient temperature of the MCB installation exceeds 30°C or multiple MCBs are installed side by side, the number of drives mounted will be reduced and the calculation needs to be recalculated.
- Electrician's usually consider Type B for household lighting and Type C for commercial lighting application.

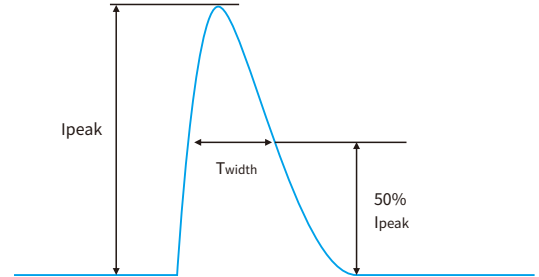

## Functions

### Output short-circuit behaviour

- Output short-circuit will not damage the driver.  
After removing the short circuit fault, the driver will automatically resume output.

### Output no-load operation

- Output no-load will not damage the driver.  
Please turn off the driver first if you need to connect the LED load.

### Output hot plug-in

In the following two cases, the LED driver will automatically turn off the output to protect the LED:

- When the driver is powered on first and the LED is connected later.
  - When the driver is powered on, disconnected and connected again.
- The output will be activated again after restart of the LED driver.

### Driver restart method

There are two ways to restart the driver:

- Through the AC input: disconnect the AC of the driver and power it again.
- Through dimming interface.

DALI: send "OFF" command first, then send "MAX" command.

pushDIM: short press pushbutton two times, then long press pushbutton.

1-10V: first adjust the output voltage of the dimmer to 0.9V or below, then adjust it to 1V or above.

DIP-switch & output current

Label

BK-PUL030A-0700AD

PIN(W) typ.	Output Prated(W)	Output Irated(mA)	Output Voltage(VDC)	1	2	3	4
12.7	10.5	250	3-42	--	ON	ON	ON
14.9	12.6	300	3-42	ON	--	ON	ON
17.4	14.7	350	3-42	--	--	ON	ON
19.5	16.8	400	3-42	--	ON	--	ON
21.9	18.9	450	3-42	--	--	--	ON
24.3	21.0	500	3-42	ON	ON	ON	--
26.5	23.1	550	3-42	--	--	ON	--
28.9	25.2	600	3-42	--	ON	--	--
31.3	27.3	650	3-42	ON	--	--	--
33.7	29.4	700 ★	3-42	--	--	--	--

**BOKE Dimmable Constant Current LED Driver**  
**MODEL: BK-PUL030A-0700AD**  
 INPUT: 200-240VAC ~ 50/60Hz 0.2A Max  $\lambda$ :0.95  
 OUTPUT: 50V ~ Max other ratings see below sheet

Switching selection sheet

Pin typ.	Irated	Output Voltage	Prated	1	2	3	4
12.7W	250mA	3-42VDC	10.5W	ON	ON	ON	ON
14.9W	300mA	3-42VDC	12.6W	ON	ON	ON	ON
17.4W	350mA	3-42VDC	14.7W	ON	ON	ON	ON
19.5W	400mA	3-42VDC	16.8W	ON	ON	ON	ON
21.9W	450mA	3-42VDC	18.9W	ON	ON	ON	ON
24.3W	500mA	3-42VDC	21.0W	ON	ON	ON	ON
26.5W	550mA	3-42VDC	23.1W	ON	ON	ON	ON
28.9W	600mA	3-42VDC	25.2W	ON	ON	ON	ON
31.3W	650mA	3-42VDC	27.3W	ON	ON	ON	ON
33.7W	700mA	3-42VDC	29.4W	ON	ON	ON	ON

Before use, always check dipswitch settings!  
 • tc = 75°C  
 ta = 45°C  
 MADE IN CHINA  
 For LED Modules use only

LED -  
 LED +  
 DIM +  
 DIM -

SEC wire prep. 0.5-1.5mm<sup>2</sup>  
 PRI wire prep. 0.75mm<sup>2</sup>

DA  
 DA  
 ACN  
 ACL

BK-PUL042A-0700BD

PIN(W) typ.	Output Prated(W)	Output Irated(mA)	Output Voltage(VDC)	1	2	3	4
24	21.0	250	3-84	--	ON	ON	ON
29	25.2	300	3-84	ON	--	ON	ON
33	29.4	350	3-84	--	--	ON	ON
38	33.6	400	3-84	--	ON	--	ON
42	37.8	450	3-84	--	--	--	ON
47	42.0	500	3-84	ON	ON	ON	--
47	41.8	550	3-76	--	--	ON	--
47	42.0	600	3-70	--	ON	--	--
47	41.6	650	3-64	ON	--	--	--
48	42.0	700 ★	3-60	--	--	--	--

**BOKE Dimmable Constant Current LED Driver**  
**MODEL: BK-PUL042A-0700BD**  
 INPUT: 200-240VAC ~ 50/60Hz 0.3A Max  $\lambda$ :0.95  
 OUTPUT: 100V ~ Max other ratings see below sheet

Switching selection sheet

Pin	Irated	Output Voltage	Prated	1	2	3	4
24W	250mA	3-84VDC	21W	ON	ON	ON	ON
29W	300mA	3-84VDC	25.2W	ON	ON	ON	ON
33W	350mA	3-84VDC	29.4W	ON	ON	ON	ON
38W	400mA	3-84VDC	33.6W	ON	ON	ON	ON
42W	450mA	3-84VDC	37.8W	ON	ON	ON	ON
47W	500mA	3-84VDC	42W	ON	ON	ON	ON
47W	550mA	3-76VDC	41.8W	ON	ON	ON	ON
47W	600mA	3-70VDC	42W	ON	ON	ON	ON
47W	650mA	3-64VDC	41.6W	ON	ON	ON	ON
48W	700mA	3-60VDC	42W	ON	ON	ON	ON

Before use, always check dipswitch settings!  
 • tc = 75°C  
 ta = 45°C  
 MADE IN CHINA  
 For LED Modules use only

LED -  
 LED +  
 DIM +  
 DIM -

SEC wire prep. 0.5-1.5mm<sup>2</sup>  
 PRI wire prep. 0.75mm<sup>2</sup>

DA  
 DA  
 ACN  
 ACL

BK-PUL042A-1100AD

PIN(W) typ.	Output Prated(W)	Output Irated(mA)	Output Voltage(VDC)	1	2	3	4
29	25.2	600	3-42	--	ON	ON	ON
34	29.4	700	3-42	ON	--	ON	ON
36	31.5	750	3-42	--	--	ON	ON
39	33.6	800	3-42	--	ON	--	ON
41	35.7	850	3-42	--	--	--	ON
43	37.8	900	3-42	ON	ON	ON	--
46	39.9	950	3-42	--	--	ON	--
48	42.0	1000	3-42	--	ON	--	--
48	42.0	1050	3-40	ON	--	--	--
48	41.8	1100 ★	3-38	--	--	--	--

**BOKE Dimmable Constant Current LED Driver**  
**MODEL: BK-PUL042A-1100AD**  
 INPUT: 200-240VAC ~ 50/60Hz 0.3A Max  $\lambda$ :0.95  
 OUTPUT: 50V ~ Max other ratings see below sheet

Switching selection sheet

Pin	Irated	Output Voltage	Prated	1	2	3	4
29W	600mA	3-42VDC	25.2W	ON	ON	ON	ON
34W	700mA	3-42VDC	29.4W	ON	ON	ON	ON
36W	750mA	3-42VDC	31.5W	ON	ON	ON	ON
39W	800mA	3-42VDC	33.6W	ON	ON	ON	ON
41W	850mA	3-42VDC	35.7W	ON	ON	ON	ON
43W	900mA	3-42VDC	37.8W	ON	ON	ON	ON
46W	950mA	3-42VDC	39.9W	ON	ON	ON	ON
48W	1000mA	3-42VDC	42W	ON	ON	ON	ON
48W	1050mA	3-40VDC	42W	ON	ON	ON	ON
48W	1100mA	3-38VDC	41.8W	ON	ON	ON	ON

Before use, always check dipswitch settings!  
 • tc = 75°C  
 ta = 45°C  
 MADE IN CHINA  
 For LED Modules use only

LED -  
 LED +  
 DIM +  
 DIM -

SEC wire prep. 0.5-1.5mm<sup>2</sup>  
 PRI wire prep. 0.75mm<sup>2</sup>

DA  
 DA  
 ACN  
 ACL

BK-PUL060A-2000AD

PIN(W) typ.	Output Prated(W)	Output Irated(mA)	Output Voltage(VDC)	1	2	3	4	5	6
38	33.6	800	3-42	ON	--	ON	--	ON	ON
43	37.8	900	3-42	--	--	ON	--	--	ON
47	42.0	1000	3-42	ON	ON	ON	--	ON	--
52	46.2	1100	3-42	--	--	--	--	ON	--
54	48.3	1150	3-42	--	--	--	--	ON	--
56	50.4	1200	3-42	--	ON	ON	ON	--	--
59	52.5	1250	3-42	ON	--	ON	ON	--	--
59W	52.5W	1250mA	3-42VDC	50.4W	ON	ON	ON	ON	ON
59W	52.5W	1250mA	3-42VDC	52.5W	ON	ON	ON	ON	ON
61W	54.6W	1300mA	3-42VDC	54.6W	ON	ON	ON	ON	ON
65W	58.8W	1400mA	3-42VDC	58.8W	ON	ON	ON	ON	ON
68W	60.0W	1500mA	3-40VDC	60.0W	ON	ON	ON	ON	ON
69W	60.8W	1600mA	3-38VDC	61.2W	ON	ON	ON	ON	ON
69W	61.2W	1700mA	3-36VDC	60.8W	ON	ON	ON	ON	ON
69W	61.2W	1800mA	3-34VDC	60.8W	ON	ON	ON	ON	ON
69W	60.8W	1900mA	3-32VDC	60.8W	ON	ON	ON	ON	ON
69W	60.0W	2000mA	3-30VDC	60W	ON	ON	ON	ON	ON

**BOKE Dimmable Constant Current LED Driver**  
**MODEL: BK-PUL060A-2000AD**  
 INPUT: 200-240VAC ~ 50/60Hz 0.4A Max  $\lambda$ :0.95  
 OUTPUT: 50V ~ Max other ratings see below sheet

Switching selection sheet

Pin	Irated	Output Voltage	Prated	1	2	3	4	5	6
38W	800mA	3-42VDC	33.6W	ON	ON	ON	ON	ON	ON
43W	900mA	3-42VDC	37.8W	ON	ON	ON	ON	ON	ON
47W	1000mA	3-42VDC	42W	ON	ON	ON	ON	ON	ON
52W	1100mA	3-42VDC	46.2W	ON	ON	ON	ON	ON	ON
54W	1150mA	3-42VDC	48.3W	ON	ON	ON	ON	ON	ON
56W	1200mA	3-42VDC	50.4W	ON	ON	ON	ON	ON	ON
59W	1250mA	3-42VDC	52.5W	ON	ON	ON	ON	ON	ON
61W	1300mA	3-42VDC	54.6W	ON	ON	ON	ON	ON	ON
65W	1400mA	3-42VDC	58.8W	ON	ON	ON	ON	ON	ON
68W	1500mA	3-40VDC	60W	ON	ON	ON	ON	ON	ON
69W	1600mA	3-38VDC	60.8W	ON	ON	ON	ON	ON	ON
69W	1700mA	3-36VDC	61.2W	ON	ON	ON	ON	ON	ON
69W	1800mA	3-34VDC	61.2W	ON	ON	ON	ON	ON	ON
69W	1900mA	3-32VDC	60.8W	ON	ON	ON	ON	ON	ON
69W	2000mA	3-30VDC	60W	ON	ON	ON	ON	ON	ON

Before use, always check dipswitch settings!  
 • tc = 80°C  
 ta = 45°C  
 MADE IN CHINA  
 For LED Modules use only

LED -  
 LED +  
 DIM +  
 DIM -

SEC wire prep. 0.5-1.5mm<sup>2</sup>  
 PRI wire prep. 0.75mm<sup>2</sup>

DA  
 DA  
 ACN  
 ACL

Remarks:

- ★ It means that this item is the factory default current.
- It means that this channel is OFF.

## DALI dimming application

### Wiring diagram

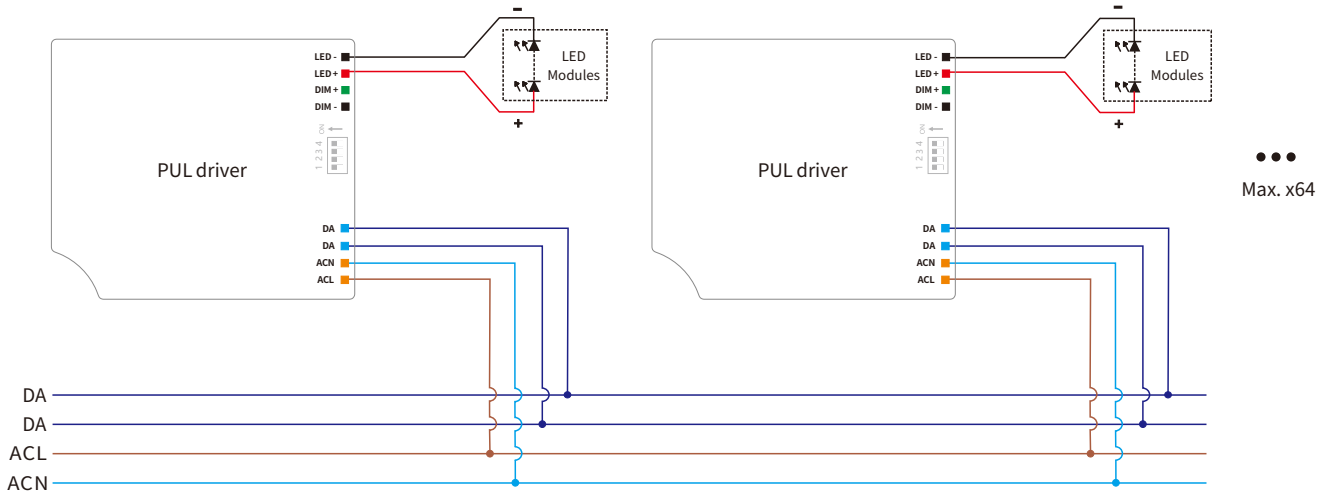

### Switch to the DALI dimming mode

- After installation according to the wiring diagram of DALI dimming application, the driver will automatically switch to the DALI control mode after receiving any DALI command.

#### Remarks:

- Standard DALI control line voltage range: 9.5V to 22.5V, type 16V.
- The two DALI control lines polarity-reversible.
- Max. 64 DALI drivers per DALI control line.
- The maximum distance length of the DALI control line is 300m at  $2 \times 1.5\text{mm}^2$ .
- DALI bus can be wired together with any mains voltage cables, but separate wiring is recommended.

Please refer to the table below

Cable size	Distance
$2 \times 0.5\text{mm}^2$	max.100m
$2 \times 0.75\text{mm}^2$	max.150m
$2 \times 1.00\text{mm}^2$	max.200m
$\geq 2 \times 1.50\text{mm}^2$	max.300m

### Dimming curve

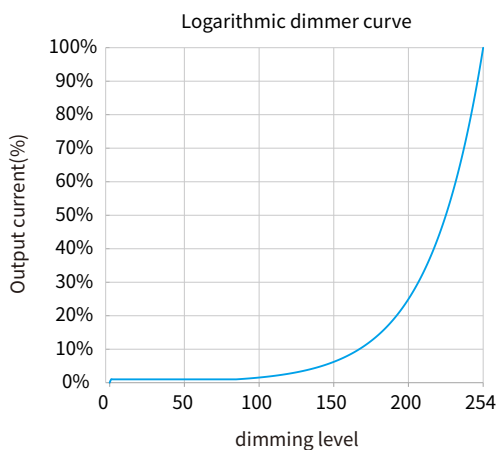

#### Remarks:

The dimming curve can be selected by DALI configuration. The default is logarithmic dimming curve.

**pushDIM dimming application**

**Wiring diagram**

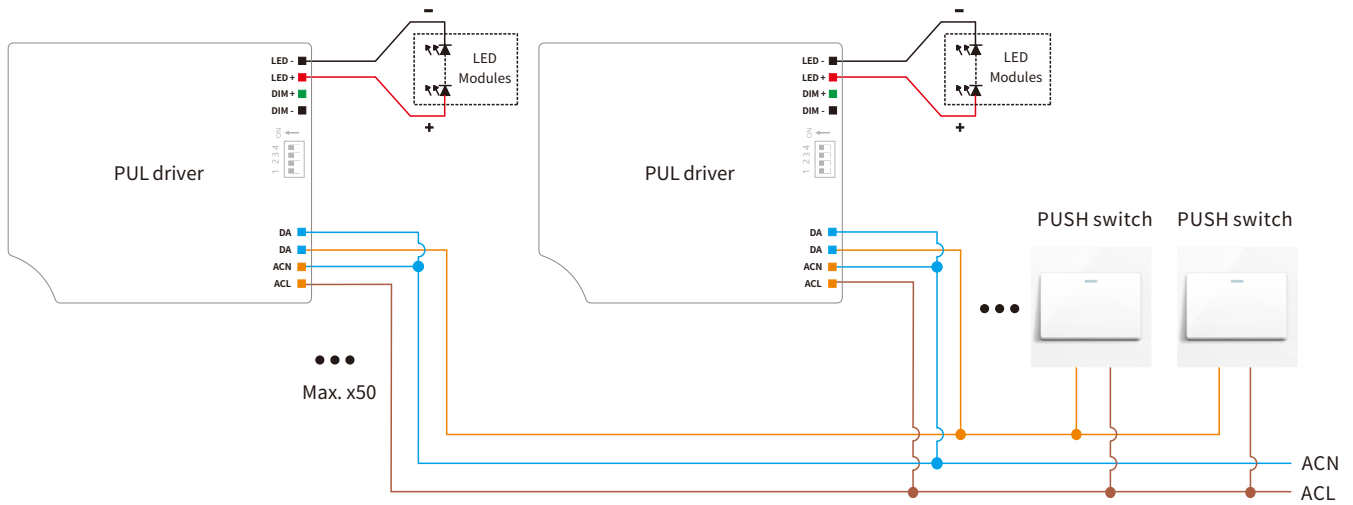

**Switch to the pushDIM dimming mode**

- After installation according to the wiring diagram of pushDIM dimming application, short press the pushbutton, the driver will automatically switch to the pushDIM dimming mode.

**Remarks:**

Max. 50 drivers per pushDIM control line.

Turn on or turn off:short press pushbutton for 0.2-1s.

Dimming: long press pushbutton for 1-5s.

Power on status: after power on,the light state will be the same as the lighting on state.

If the light is on before power on,the light will be on after power on again,brightness will be the same as the last lighting on brightness.

If the light is off before power off,the light will be off after power on again,short press the pushbutton,then the light will be on,the brightness will be the same as the last brightness.

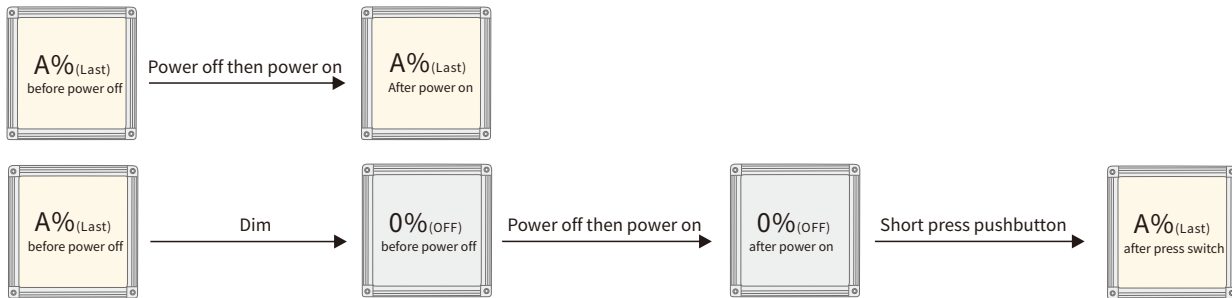

**Multiple lights synchronize control operation**

method 1:

Step 1:long press the pushbutton,confirm each light is on.

Step 2:short press the pushbutton,confirm each light is off.

Step 3:long press the pushbutton,confirm each light is from darkest to brightest and all the lights are synchronous.

**1-10V/10V PWM dimming application**

**Wiring diagram**

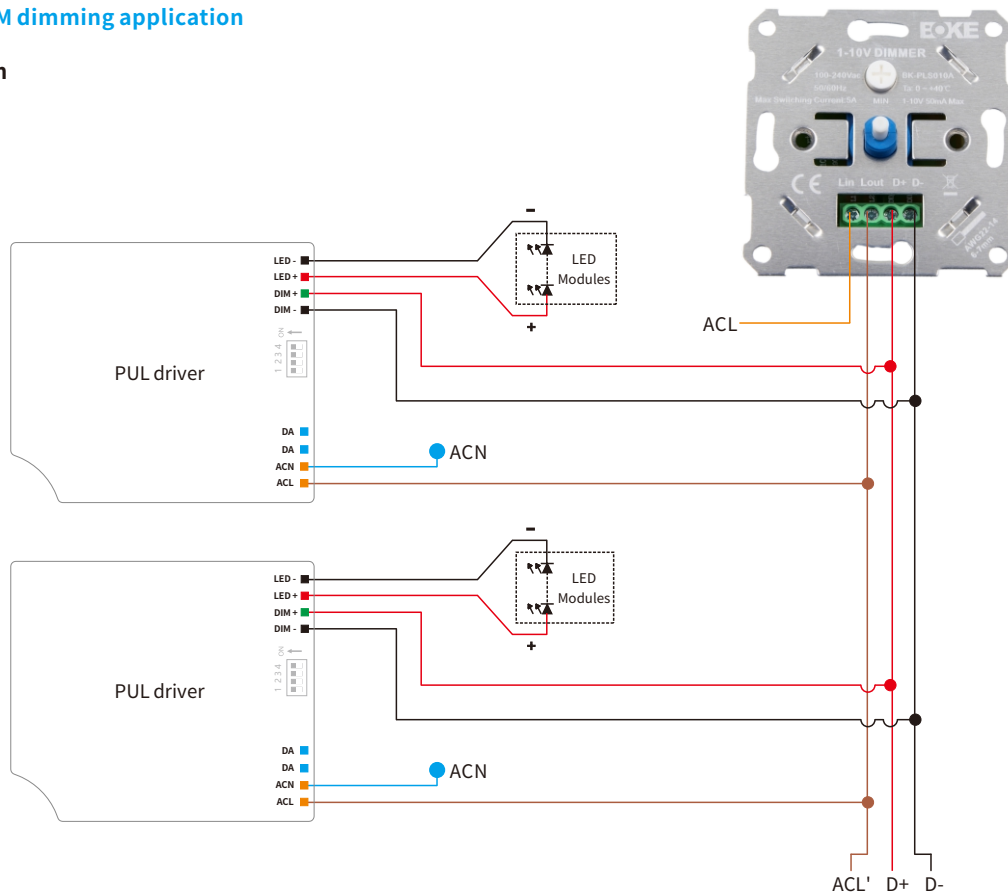

**Switch to the 1-10V / 10V PWM dimming mode**

- Method 1: After installation according to the wiring diagram of the 1-10V / 10V PWM dimming application, adjust the dimmer to the minimum and then to the maximum, the driver will automatically activate the 1-10V control mode.
- Method 2: Short-circuit the DIM+ and DIM- ports for 2s, the driver will automatically activate the 1-10V control mode.

**Remarks**

- Dimming interface characteristics: 0.9V and below are closed, 1V is the darkest, 10V is the brightest, 1-10V is the dimming range.
- The dimming interface distinguishes between positive and negative, DIM+ is positive, DIM- is negative, please do not reverse.
- Dimming interface does not support voltage access higher than 20V, otherwise it will cause damage to the internal components.
- When the dimming interface is open, the driver outputs the maximum current. When the interface is short-circuited, the current output is closed.
- When multiple synchronous dimming is required, the positive poles of the dimming interface of each driver are connected together, and the negative poles are connected together.
- Support passive dimmer or isolated active dimmer dimming, does not support non-isolated active dimmer dimming.
- In general, it is recommended that the number of mounted drives does not exceed 30pcs, and the wiring length does not exceed 100m.
- It is recommended that the dimming wires should not be lower than the 22AWG wire.
- Do not put the dimming wires with high voltage or interference sources. If it is unavoidable, please use the shielded wires.
- If you need a drive with 0-10V dimming characteristics, please contact BOKE.

**Dimming curve**

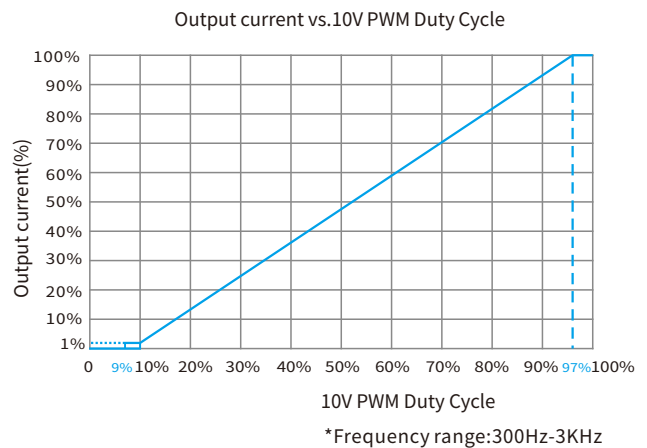
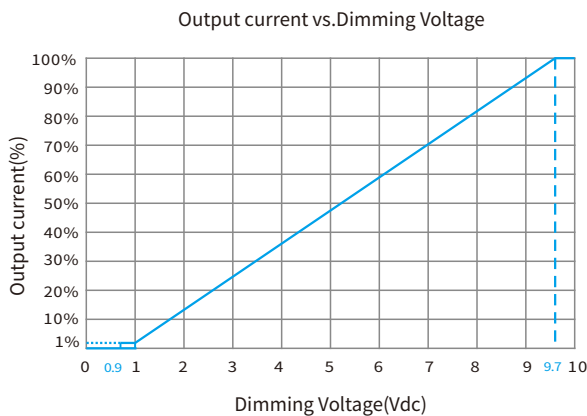

**Installation**

**Mechanical dimensions**

Unit:mm

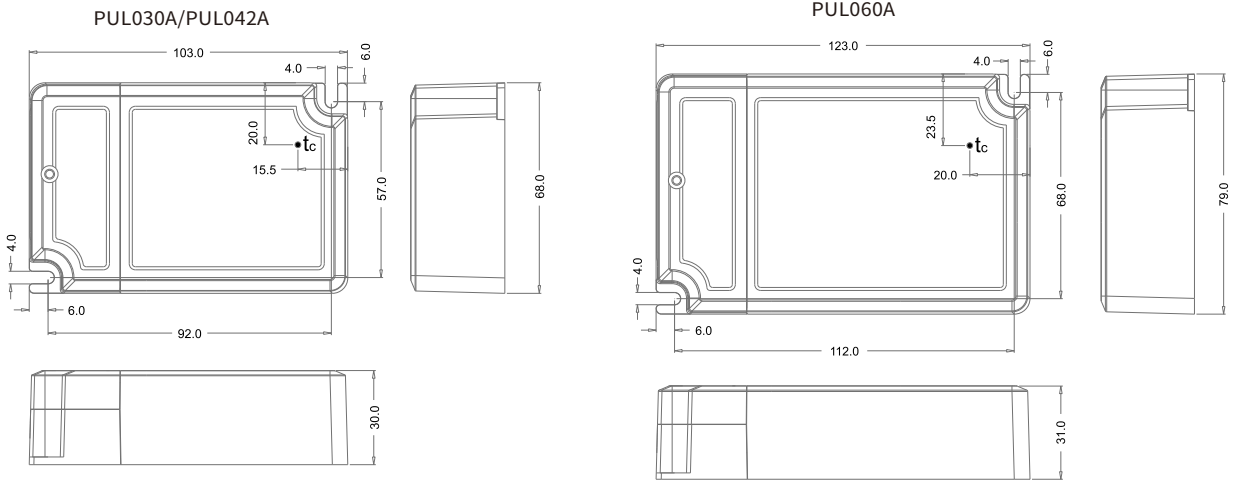

**INPUT**

Numbering	function	colour
1	ACL	orange
2	ACN	orange
3	DA	blue
4	DA	blue

**Input wire**

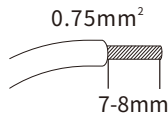

**OUTPUT**

Numbering	function	colour
1	LED-	black
2	LED+	red

**Output wire**

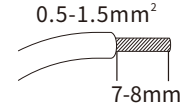

**Installation note**

**Hot plug-in**

- Hot plug-in is not supported due to residual output voltage of > 0 V.
- If a LED load is connected the device has to be restarted.
- Restart can be achieved by re-powering the driver or executing a on/off command (action) through the control interface (DALI)

**Wiring guidelines**

- All connections must be kept as short as possible to ensure good EMI behaviour.
- Mains leads should be kept apart from LED Driver and other leads (ideally 5 – 10 cm distance)
- Max. length of output wires is 2 m.
- Incorrect wiring can damage LED modules.

**Installation requirements**

- The driver should be installed in a dry, acid-free, oil-free, fat-free environment.
- The installation ambient temperature of the drive shall not exceed the value of Ta at any time.
- The temperature of the mounting surface of the driver should be lower than 40°C
- The driver should keep a certain distance from the heating stuff (such as the luminaire radiator).
- If the driver is used externally (it needs to be used with the accessories), the installation of the driver should also meet the following conditions:
  - 1.The driver should be a certain distance between the drivers, as shown in Figure 1.
  - 2.The driver keeps a certain distance from surrounding objects, as shown in Figure 2.

**Mounting screw specifications and torque**

- Max. torque at the clamping screw: 0.5 Nm / M4

**Replace LED module**

1. Mains off
2. Remove LED module
3. Wait for 5 seconds
4. Connect LED module again

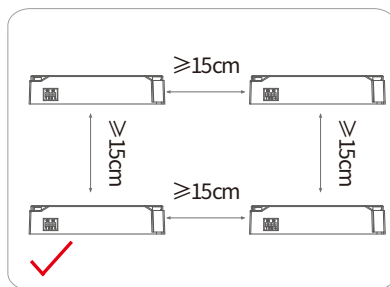
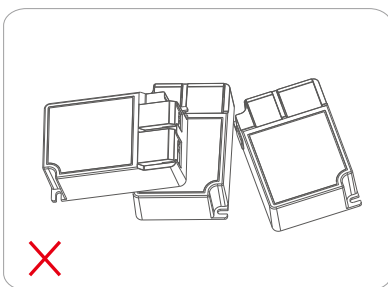

Figure 1

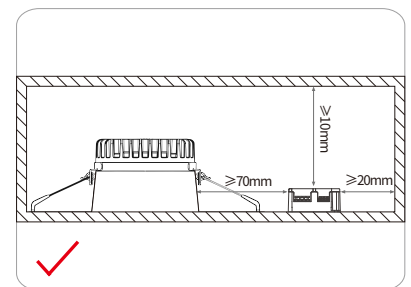

Figure 2

